



# MICRON Engineering Works

Pollachi Main Road, Eachanari, Coimbatore - 641 021.  
Tamil nadu, India.

Mob : 94437 03029 | 86108 41348 | 97912 84504

E-mail : microndrilljigbushes@gmail.com, micronmohan@gmail.com

<https://drilljigbushescoimbatore.com>

**IMPORTER / EXPORTER**



## MANUFACTURERS OF :

1. DRILL JIG BUSHES (FOR IS STD & DIN STD)  
IS 666 (Part I & II) - 1972 | DIN STD : 172, 179, 173-1  
CUSTOMERIZED requirements
2. H.S.S. BACK SPOT FACE CUTTERS & HOLDERS
3. MT 1 to MT 6 most Taper Mandrels (IS 1715)
4. Drill Jig
5. Locating pin & bush
6. Precision Cylindrical parts, Spindles
7. DIE Making Accessories (Guide Pillar & Bushes, Stripper Bushes)



**IS : 666 (Part I) -1972**  
**SPECIFICATION FOR HEADED & HEADLESS JIG BUSHES**

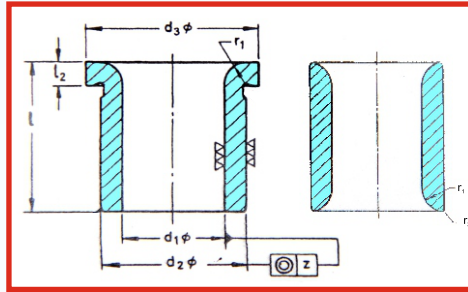

$d_1^* F_7$		$l$		$l_2$	$d_2$ $n_6$	$d_3$	$r_1$	$r_2$	$z$
Over	Up to	Short	Long						
	1	6	9	2	3	6	1.2	0.2	0.01
1	1.8				4	7			
1.8	2.6				5	8			
2.6	3.3	8	12	2.5	6	10	1.6	0.3	
3.3	4				7	11			
4	5				8	12			
5	6	10	16	3	10	14	2	0.4	
6	8				12	16			
8	10				15	19			
10	12	12	20	4	18	22	2.5	0.8	
12	15				22	26			
15	18				26	30			
18	22	20	36	5	30	35	6	1	
22	26				35	40			
26	30				42	47			
30	35	25	45	5	48	55	8	1.6	
35	42				55	62			
42	48				62	69			
48	55	30	56	6	70	77	8	1.6	
55	63				78	85			
					35	72			6

**IS : 666 (Part II) -1972**  
**DIMENSION FOR HEADED & HEADLESS LINER BUSHES**

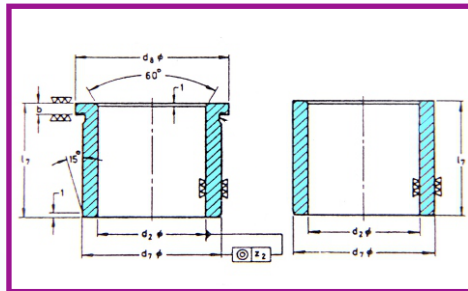

$d_2$ H7	$l_7$		$b$	$d_7$ m6	$d_8$	$z_2$
	Short	Long				
8	8	12.5	2	12	15	0.01
10	10	16		15	18	
15	12.5	20		20	24	
22	16	25	2.5	28	32	0.02
28	20	32		36	40	
35				46	50	
46	25	40	4	56	60	0.03
58				70	74	



IS : 666 (Part II) -1972

## DIMENSION FOR RENEWABLE DRILL BUSHES

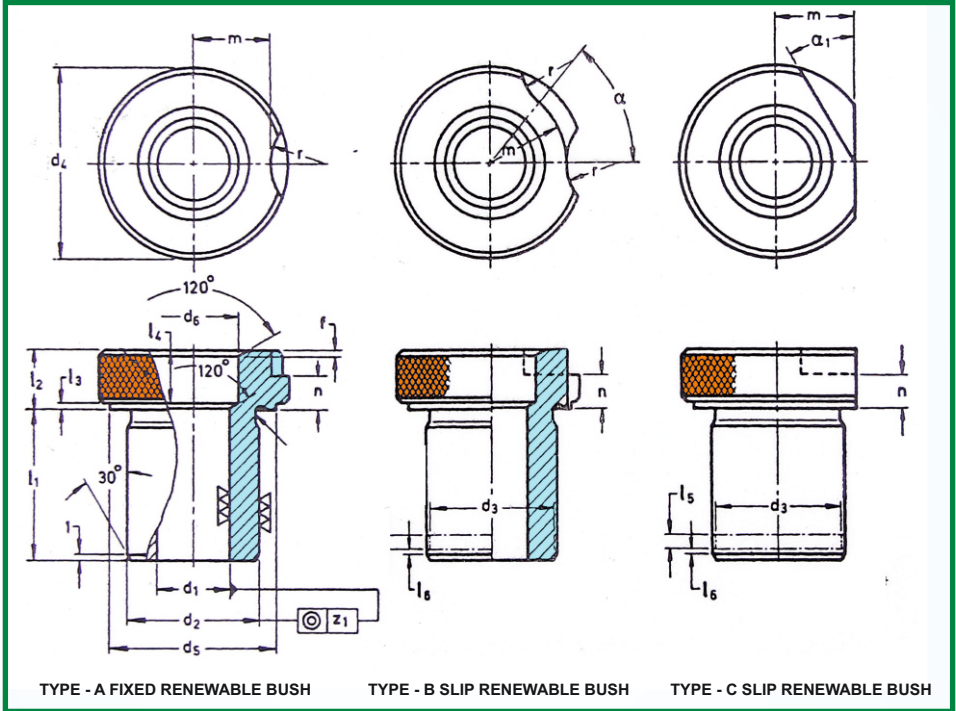

TYPE - A FIXED RENEWABLE BUSH

TYPE - B SLIP RENEWABLE BUSH

TYPE - C SLIP RENEWABLE BUSH

$d_1$ G7		$d_2^+$	$d_3$	$d_4$	$d_5$	$d_6^+$	$f$	$l_1$			$l_2$	$l_3$	$l_4$		$l_5$	$l_6$	$m$	$n$	$r$	$Z_1$	$\alpha$	$\alpha_1$
Over	Up to	$h_6$						Short	Medium	Long			For $l_1$ Medium	For $l_1$ Long								
-	2.65	8	7.8	15	12	3	0.5	8	12.5	-	8	1	4.5		0.8	0.2	5	4.5	7	0.02	65°	40°
2.65	4.75	10	9.7	18	15	5		10	16	25			6	15	1	0.25	6.5					
4.75	8.5	15	14.5	24	20	9	0.8	12.5	20	32	10	1	8	20	1.6	0.3	9	5.5	9	0.03	50°	30°
8.5	14.0	22	21.4	32	28	14.5		16	25	40					9	24	2.2					
14.0	19.0	28	27.2	40	36	20	1.2	20	32	50	12	1.5	12	30	2.8	0.6	17	7			30°	20°
19.0	25.0	35	34	50	46	26											3.5					
25.0	33.5	46	44.6	60	56	35	1.6	25	40	63	16	2	15	38	4.5	1	26	9.5	11.5	0.04	25°	
33.5	45.0	58	56.2	74	70	47											5.6					

**MICRON Engineering Works**

Micron Drilljig Bushes

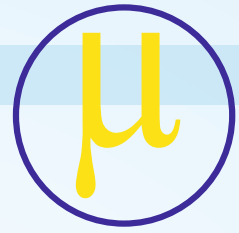

## **Company Profile**

Micron Engineering works has started its functioning at its own premises in Coimbatore in the year 2003, one of the developing companies the most reliable manufacturers of drill jig bushes with extremely high quality of product service and has number of corporate and commercial customers in India.

We perform our duties in the manufacturing line with a hi-technical know-how for meeting the utmost satisfaction and needs of our customers. Our primary aim is to adhere strict quality control and long lasting relationship with our customers and prompt delivery.

We are supplying various types of Indian Standard (IS666 PART 1972) of products like drilljig bushes. Spindle, Drill Jig, jig and fixtures and precision Taper mandrels MT1 to MT6(IS1715) extralong tool holder, Back spot facing cutters (HSS M2, M35, M42).

We assure our customers to give much concern to quality in the changing day –today trends in the industry since” Customer Is our BOSS”

**Pollachi Main Road, Eachanari, Coimbatore - 641 021.**

**Tamil nadu, India.**

**Mob : 94437 03029 | 86108 41348 | 97912 84504**

**E-mail : microndrilljigbushes@gmail.com**

**micronmohan@gmail.com**

**<https://drilljigbushescoimbatore.com>**

